

ThermaGreen Steel Structures

ASSEMBLY MANUAL

TABLE OF CONTENTS

1- INTRODUCTION

1.1 THERMAGREEN WALL PANELS

1.2 Drawing and Element Numbers

2- ASSEMBLY

2.1 Sequence of Assembly

2.2 Preparation of Foundation

2.3 Wall Assembly

2.4 Top Plates

2.5 Setting the Wall

2.6 "C" or Composite Openings for Doors, Windows, etc.

3- QUALITY CONTROL

3.1 Inspection of Panels

3.2 On-Site Changes

3.3 Dimensional Tolerances

3.4 Erection of Panels

4- SAFETY

5- DRAWINGS

1. INTRODUCTION

- 1.1 The THERMAGREEN panel is a combination of expanded polystyrene core and galvanized steel “C” channel studs. The panel has load bearing, sound transmission, thermal insulation, and vapor barrier characteristics. This manual outlines the proper methods for construction of buildings using the panel. In order to obtain the full effectiveness of the characteristics of the system, the directions found in this manual must be observed.
- 1.2 Drawings and Element Numbers. Builders should study the appropriate drawings before beginning construction and assembly. If shop drawings are provided by THERMAGREEN they show an element number for each panel in the floor plan. This element number appears on the top end of each panel. Panel drawings are viewed from the exterior. Note that the exterior face of each panel has the logo (if provided) and leading edge overlap metal.

2. ASSEMBLY

- 2.1 Sequence of Assembly. Unload the container at the job site. Stack the panels for each floor so that they are in the necessary sequence for erection. Protect panels from high winds and sharp impact. Panels are usually set starting at one corner of the building and proceeding in a counter-clockwise fashion.
- 2.2 Preparation of the Foundation. First verify that dimensions of the slab or subfloor are in accordance with contract documents and coordinate with shop drawings. These dimensions should be within the tolerances stipulated by the design professional and/or by good construction practices. Locate conduit stub-ups (if any) and drill holes in base plate.

The panels are attached to the foundation using 2x wood plates or steel channel track with anchor bolts or powder shot pins. Steel track shall be set in a waterproof inhibitor such as roofing felt, foam tape, etc. Size and spacing of anchors shall be determined by a design professional based on building code requirements.

Caulk and set baseplates or track to building dimensions and secure to the slab or subfloor using anchors as per the design drawings. Be sure the plates are level and the corners are square. If the foundation *is* not level, shim and grout with cement to obtain a level baseplate (track). Do NOT try to obtain a level wall by shimming the panels.

Once the bottom baseplates (track) are set and level, verify each panel dimension along the baseplate. Nail or screw attachment plates to both sides of baseplates as shown in Detail 1. Locate the attachment plates to fall at each panel joint and each steel stud in the panel.

- 2.3 Wall Assembly. The usual method of assembly is to pre-assemble wall sections and set them in place. Sections are usually pre-assembled in 12 ft. to 16-ft. sections. A level work area at least 16 ft. x 12 ft. is required. This area should be cleared of debris and a base line marked at the bottom and left hand side of the assembly area. The marked lines must be true and square to avoid mis-alignment of the panels.

Once the assembly area is cleared and marked, consult the floor plan and determine which sections are to be assembled and in what sequence. Using the element numbers as reference, obtain the necessary panels and lay them out with the interior face down. Caulk joints (if specified) and push the shiplaps together (Note: Each lap joint can be gaped open up to 1/4" as needed to adjust for discrepancies in wall length). Check the section for overall dimensions and for squareness. Once satisfied with the alignment, screw the panels together through the leading overlap edge metal as shown in Detail 2. Locate conduit stub-ups (if any) on panel and drill up from panel bottom (also, mark location on subfloor).

- 2.4 Top Plates. Tie Sections together using 2x wood top plates or c-channel steel top track (See specs). Cut the top plate or track on site to allow overlap to the center of the next panel section steel stud at 16" or 24". Fasten attachment plates to the top plate or track so that the attachment plates will fall at each panel joint and vertical steel stud in the panel. Drill the top plate or track to match conduit or wiring chase locations, if any, in the assembled section before attaching the plate or track to the panels. Caulk the 2x plate or track (or panel end) and attach the top plate to the wall section by placing a screw in the ends and middle section attachment plates. This connection is temporary and is used only to keep the top plate in place during erection of the walls. The top plate is permanently secured to the wall sections after the floor or roof system has been set, which loads the wall.

In cutting the top plates or track, observe the following guidelines.

- Where a wall section joins another wall section, overlap the top plate or track to the next section center of steel stud at 16" (or 24") as shown in Detail 2.
- Where a wall section joins a corner, the section top plate should overlap onto the corner to the full width of the corner on one side and width of the corner less the wall thickness on the other side.
- Where a wall section butts into another wall section, overlap the top plate the full thickness of the butt wall.
- Gap between adjacent top plates (cutting error) shall not exceed 1/2".
- Stagger top plate joints so that the joint does not fall directly over a panel joint, but does fall over the center of an inner steel stud.

- 2.5 Setting the Wall. Caulk the top of the baseplate (or track) and raise the assembled wall section into place. Connect the panels to the baseplate as shown in Detail 1 and 2. Attach the overlapping top plates (or track) to each other as shown in Detail 1 and 2. Temporarily brace the top of the wall to the ground or floor so it stands true and plumb.
- 2.6 “C” or Composite Openings for Doors, Windows, Etc. Some panel openings are assemblies consisting of 2 or more components. These are shipped disassembled and must be assembled on site. Refer to the data sheets provided and assemble these sections before setting them in place. As in all assemblies, carefully check the unit for overall dimensions and squareness before setting it into wall section.

3. QUALITY CONTROL

- 3.1 Inspection of Panels. Panels have been checked for density and fusion quality and for dimensions before shipment, but should be checked for damage and spot-checked for dimensions as they are unloaded and stacked. For dimensional tolerances refer to 3.3. As a general rule, any defect in the polystyrene core of the panel such as small cuts or nicks will not affect the integrity of the panel. Damage to the metal will affect the panel's strength and integrity and can result in a rejected panel; refer to 3.2 below.
- 3.2 On-Site Changes. in general, any changes deemed necessary on-site must be cleared with the manufacturer before the changes are made. The following site changes may be made.
- Reject any panel with vertical steel members that have any buckles or dents. The panel can be salvaged by cutting out the damaged section and inserting a wood or metal building stud. Fill gaps with insulation.
 - Bends may be straightened in the horizontal metal at the top and bottom edges of the panel.
 - Straighten any bends or dents in the leading edge overlap metal.
 - Electrical Boxes. Use a hot knife or other acceptable cutting tool. Do not exceed the box dimensions and, where possible, locate the box beside a vertical steel channel for screw attachment. Boxes should have recessed “ears” or brackets behind the wall cladding.
 - Wiring or Conduit Chases. If chases provided are not used, vertical chases may be cut in to the polystyrene with a hot knife or other acceptable cutting tool. Vertical chases shall be cut a minimum of 2” from any vertical steel channel. Do not exceed half the panel thickness in depth or 1” in width when making these cuts. Horizontal chase cuts may be extended behind the vertical metal by drilling with a 1” bit near mid-depth of the panel.

3.3 Dimensional Tolerances.

Panels:

- Thickness $\pm 1/8''$
- Panel Bow $\pm 1/8''$
- Width $+0'', -1/4''$
- Additional Width Deviation @ mid height $+0'', -1/4''$
- Length $\pm 1/4''$
- Length difference between panels of same nominal length $\pm 1/8''$
- Diagonal unsquareness $\pm 1/4''$

Door, Window, and other Rough Openings:

- Width $\pm 1/4''$
- Length $\pm 1/4''$

- Diagonal unsquareness $\pm 3/8''$

3.4 Assembly of Panels

- All bottom plates (or track) must be level before the panels are set. If shimming is necessary to obtain level bottom plate (or track) shim (and grout) under the plate and not between the panel and plate.
- Before making the final connections to the erected wall, the walls must be plumb.
- Once the panels are in place for one floor the overall dimensions and squareness of the building should be checked before proceeding with the assembly of any upper floor deck or roof system.

4. SAFETY

The panels may be handled by one or two men. The following rules should be followed:

- Gloves should be worn at all times when moving panels. The metal edges can cut and must be handled carefully.
- Do not remove panels in high wind conditions. The surface of the panel will catch the wind and can create a potentially hazardous condition.
- If high winds are possible, panels must be sheltered, weighted, or otherwise protected from moving.

TYPICAL TOP/BASE PLATE CONNECTION DETAIL

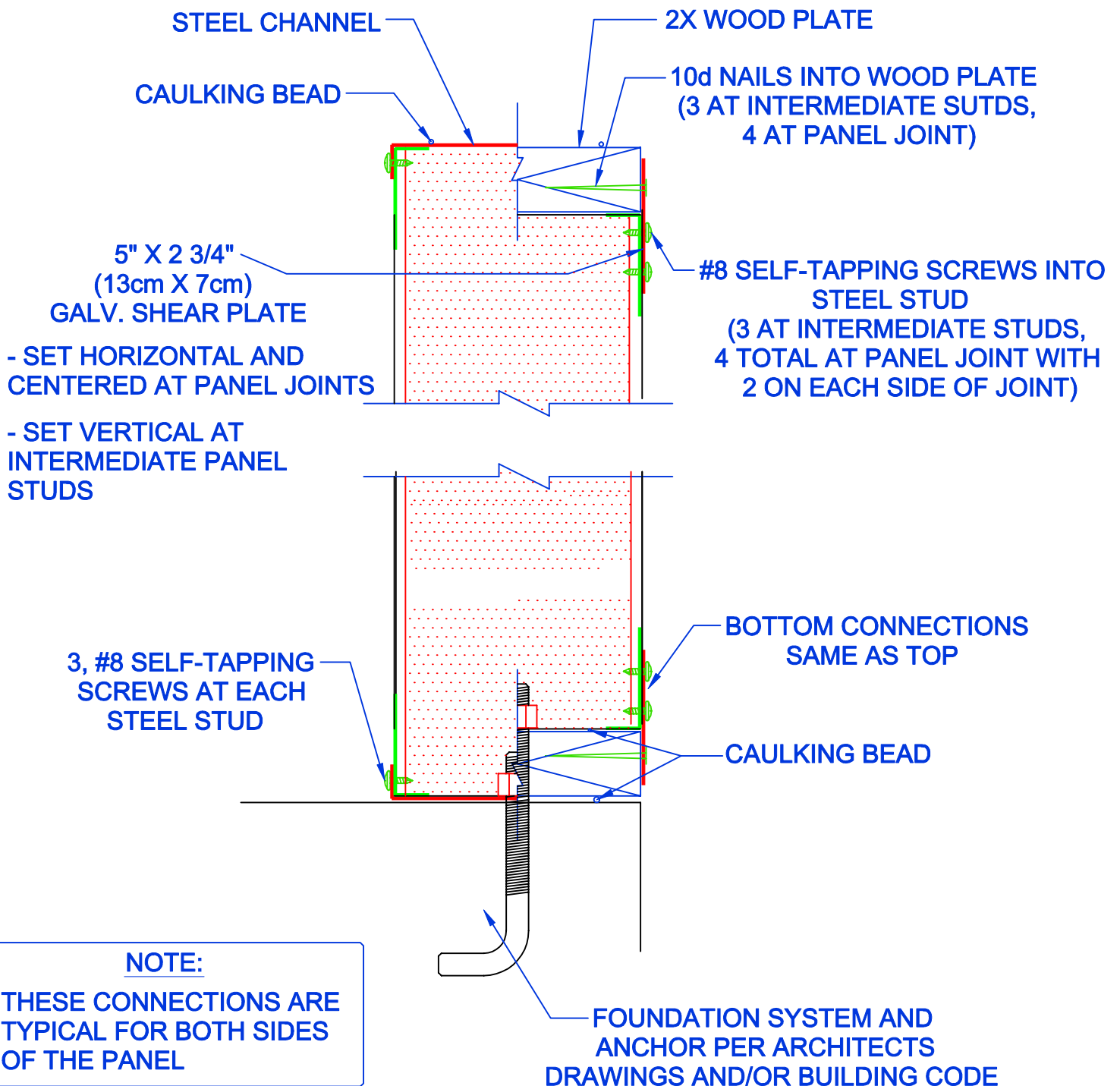

WALL SECTION ASSEMBLY

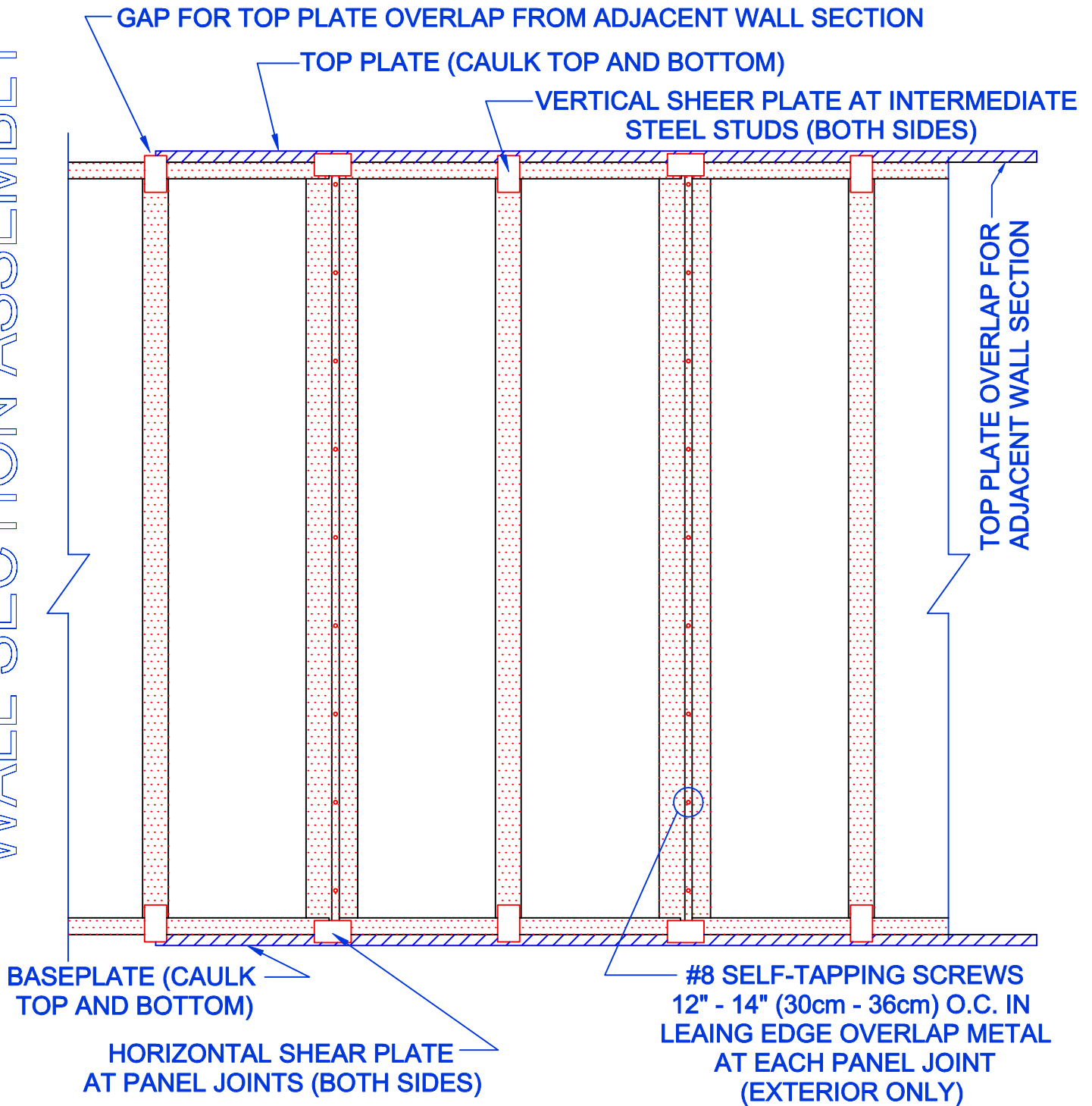

NOTE: TYPICAL SECTION IS 12' TO 16' (3.66M TO 4.88M) LONG

CONNECTION DETAILS

TABLE OF CONTENTS

Description of Detail

ThermaGreen Panel to	
<i>Metal Track Connection</i>	(A-1)
<i>Wood Plate Connection</i>	(A-2)
ThermaGreen Panel to Concrete Slab	
<i>with Anchor Pins and Metal Track</i>	(B-1)
<i>with Anchor Bolt and Metal Track</i>	(B-2)
<i>with Anchor Bolt and Wood Plate</i>	(B-3)
ThermaGreen Panel to Floor System	
<i>with Metal Track Nailed Down</i>	(B-4)
<i>with Metal Track Nailed Down and Plates to Floor System</i>	(B-5)
<i>with Wood Plate Nailed Down</i>	(B-6)
<i>with Wood Plate Nailed Down and Plates to Floor System</i>	(B-7)
ThermaGreen Roof Panel Connection	
<i>with Top Metal Track on Panel Molded to Roof Pitch</i>	(C-1)
<i>with Top Metal Track and Solid Blocking</i>	(C-2)
<i>with Top Wood Plate and Solid Blocking</i>	(C-3)
ThermaGreen Roof Panel to Pre-Engineered Truss	
<i>with (2) Top Plates and Clips as Specs.</i>	(D-1)
<i>with (2) Top Track and Clips as Specs.</i>	(D-2)
ThermaGreen Ceiling Panel to Pre-Engineered Truss	
<i>when using Rafters use same Procedure</i>	(E-1)
ThermaGreen Roof Panel to	
<i>Pre-Engineered Truss</i>	(F-1)
<i>Pre-Engineered Beam</i>	(F-2)
ThermaGreen Panel	
<i>Corner Connection</i>	(G-1)
<i>Shiplap Connection</i>	(G-2)

ThermaGreen Panel

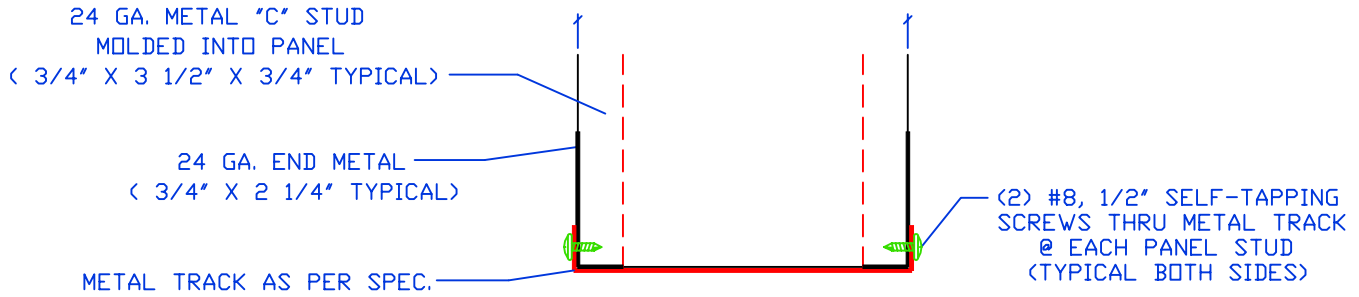

TO METAL TRACK CONNECTION
(SAME ATTACHMENT FOR TOP OF PANEL)

DRAWING A-1

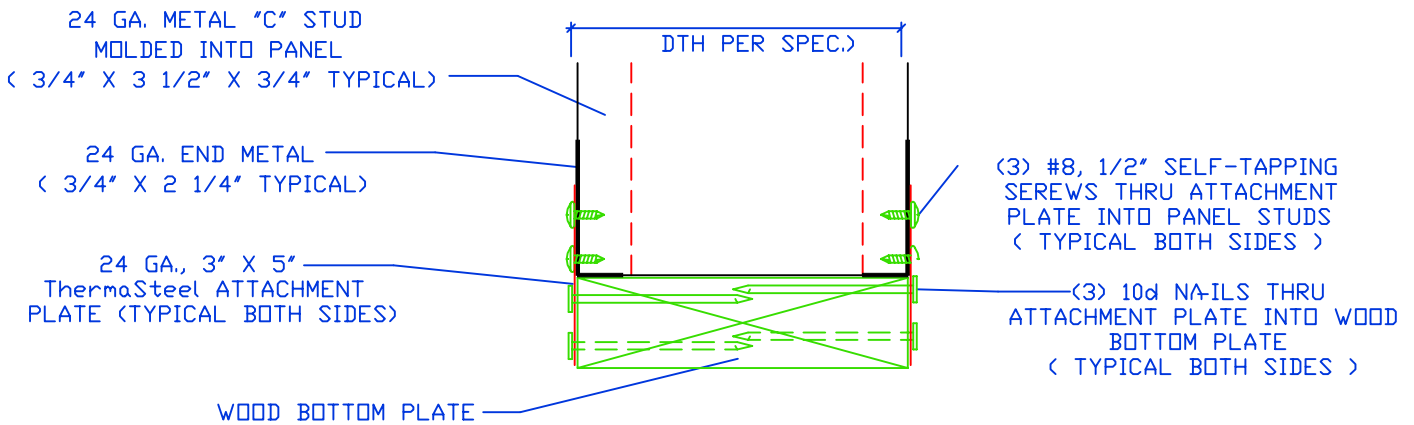

TO WOOD PLATE CONNECTION
(SAME ATTACHMENT FOR TOP OF PANEL)

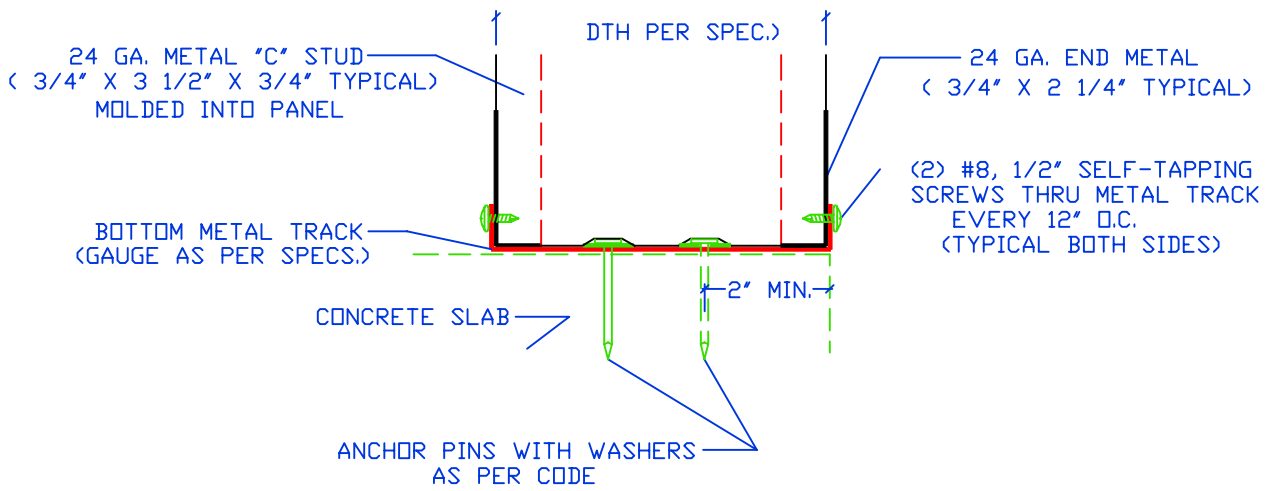

CONCRETE SLAB CONNECTION

DRAWING B-1

(WITH ANCHOR PINS AND METAL TRACK)

ThermaGreen

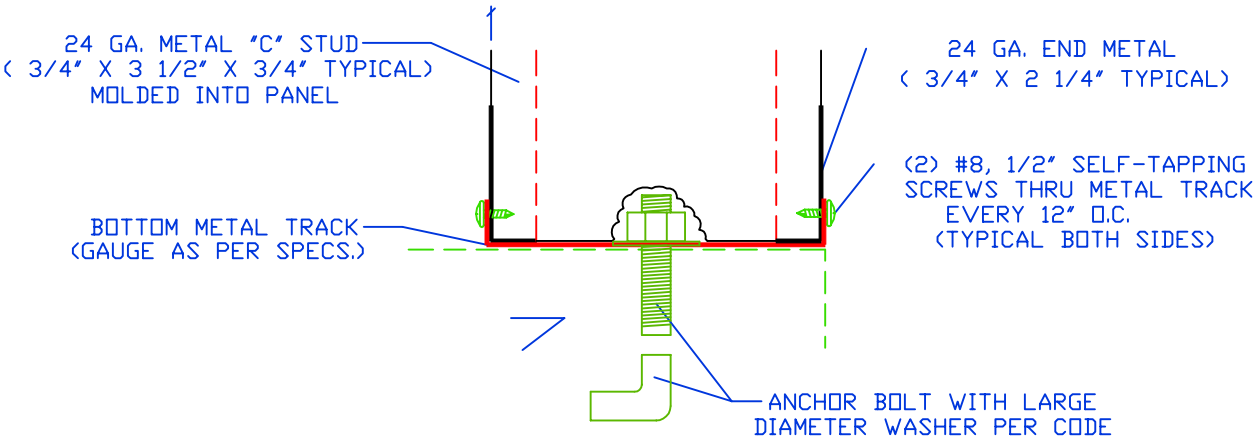

NOTE:
AN EXPANSION BOLT WITH SHIELD
MAY BE USED AS A OPTIONAL
ATTACHMENT TO SLAB

CONCRETE SLAB CONNECTION
(WITH ANCHOR BOLT AND METAL TRACK)

FIG B-2

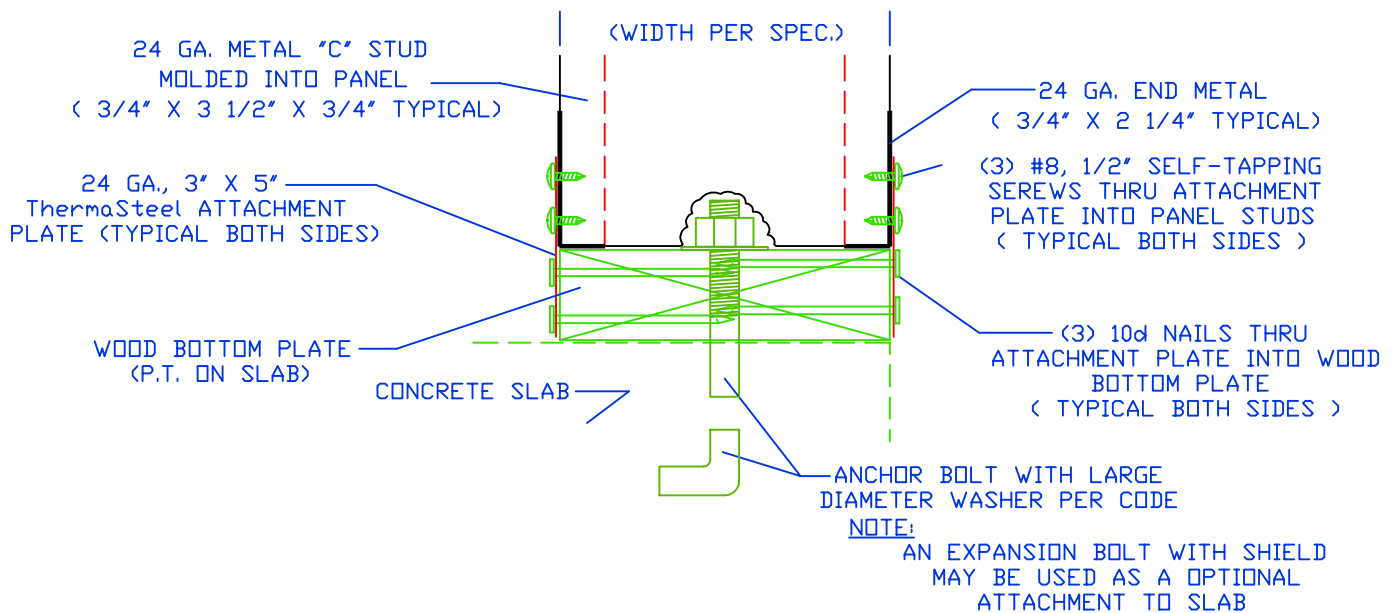

CONCRETE SLAB CONNECTION

(WITH ANCHOR BOLT AND WOOD PLATE)

FIG B-3

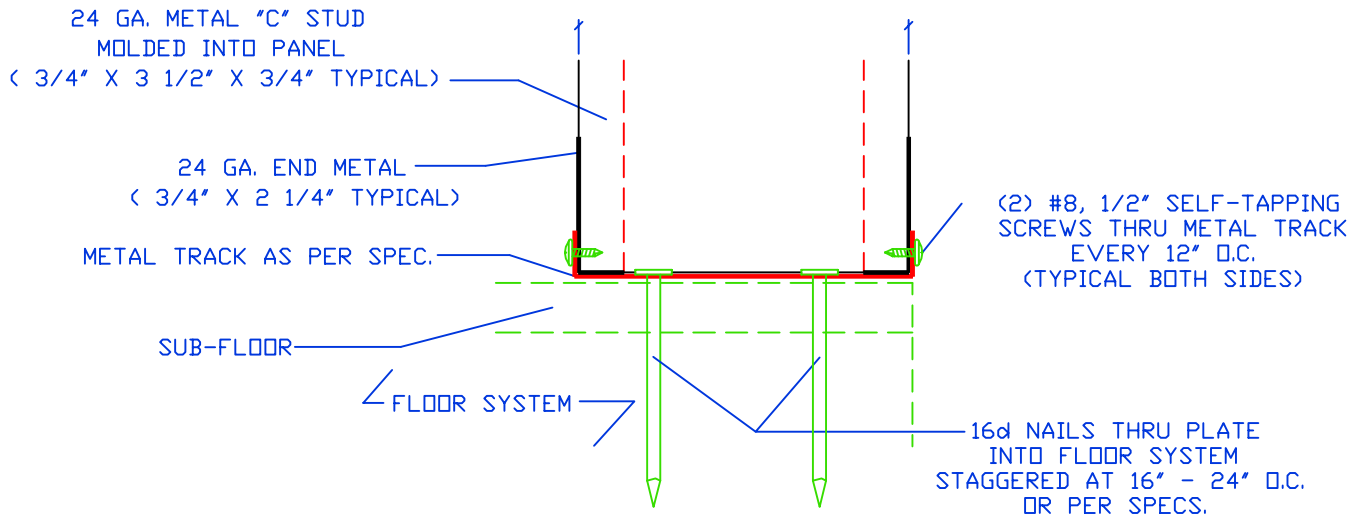

FLOOR SYSTEM CONNECTION

FIG B-4

(WITH METAL TRACK NAILED DOWN)

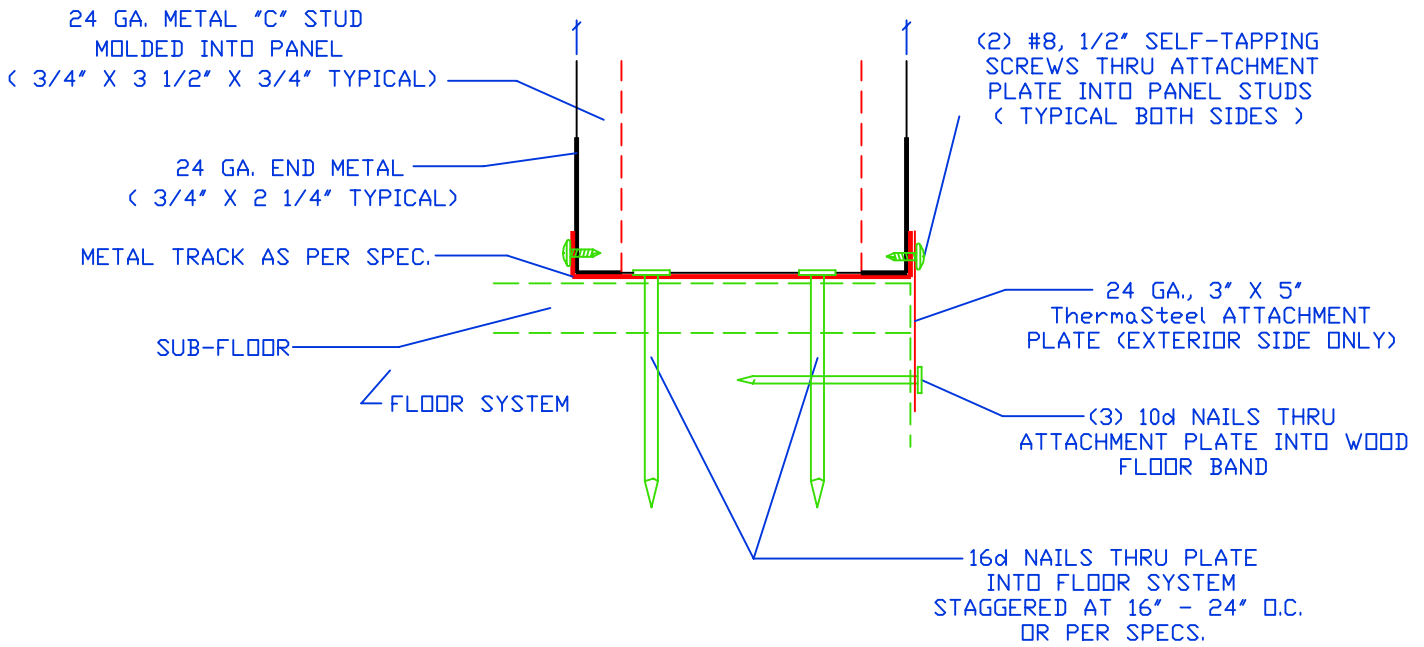

FLOOR SYSTEM CONNECTION

FIG B-5

(WITH METAL TRACK NAILED DOWN AND
ATTACHMENT PLATES TO FLOOR SYSTEM)

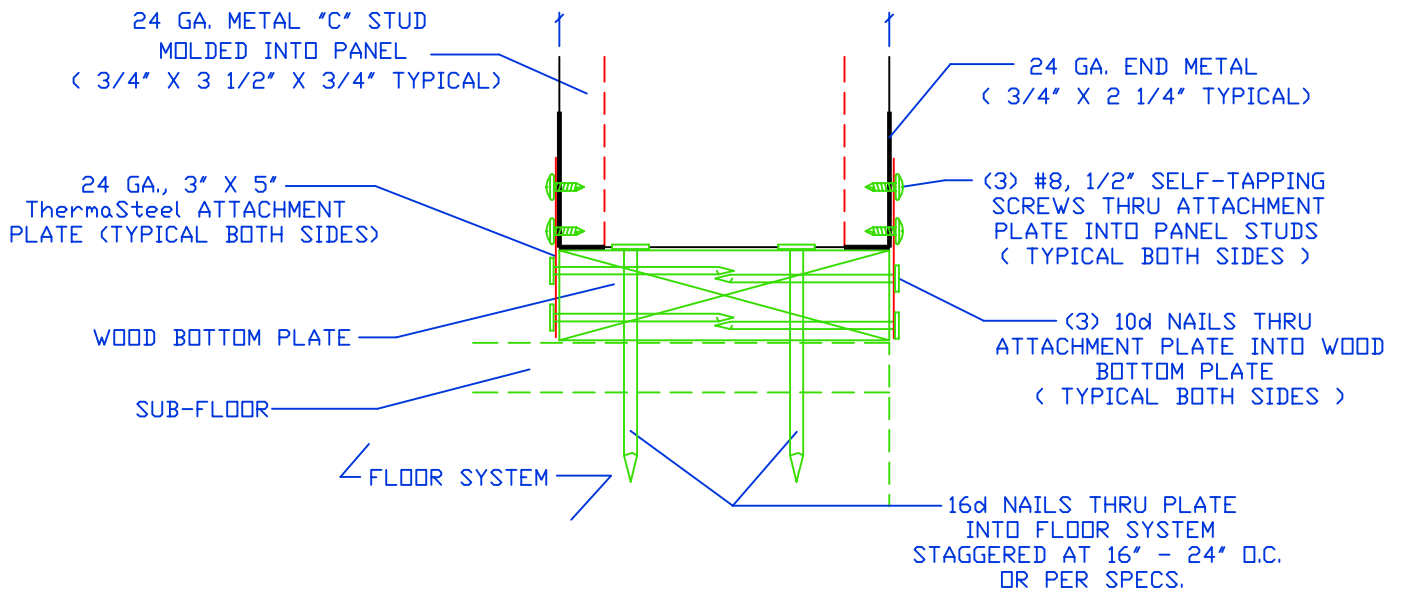

FLOOR SYSTEM CONNECTION

FIG B-6

(WITH WOOD PLATE NAILED DOWN)

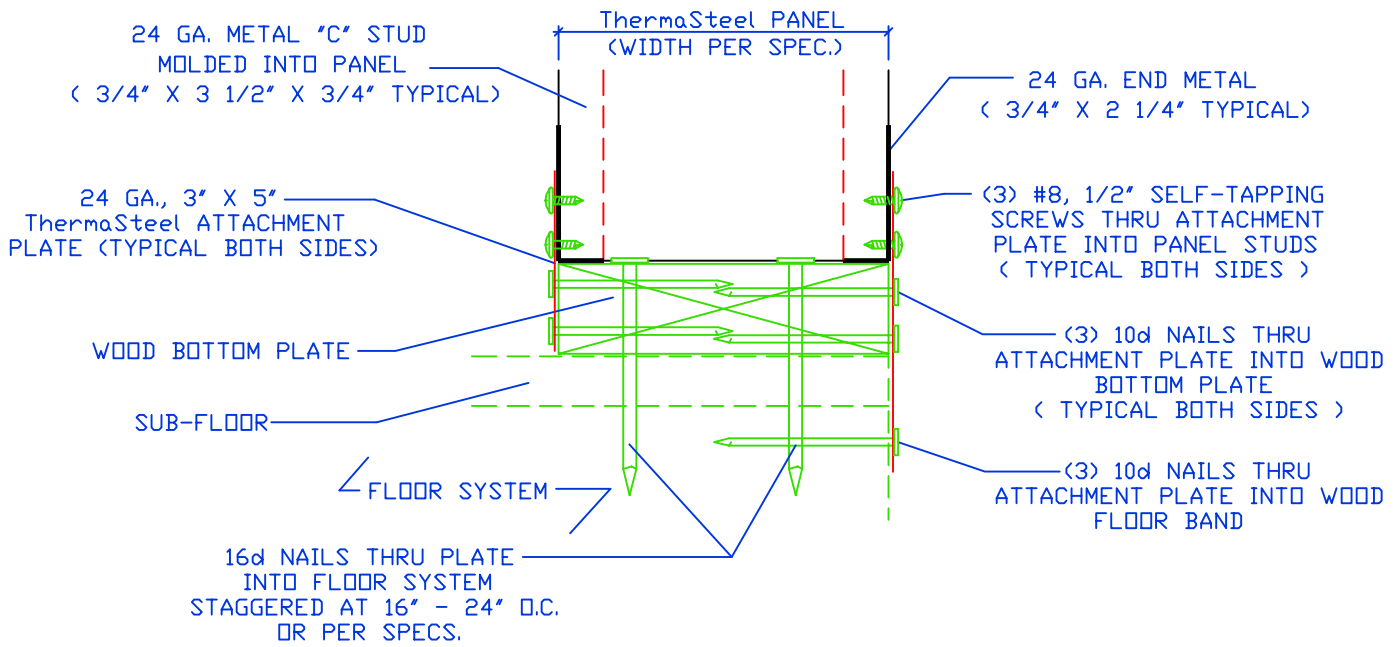

FLOOR SYSTEM CONNECTION

FIG B-7

(WITH WOOD PLATE NAILED DOWN AND
ATTACHMENT PLATES TO FLOOR SYSTEM)

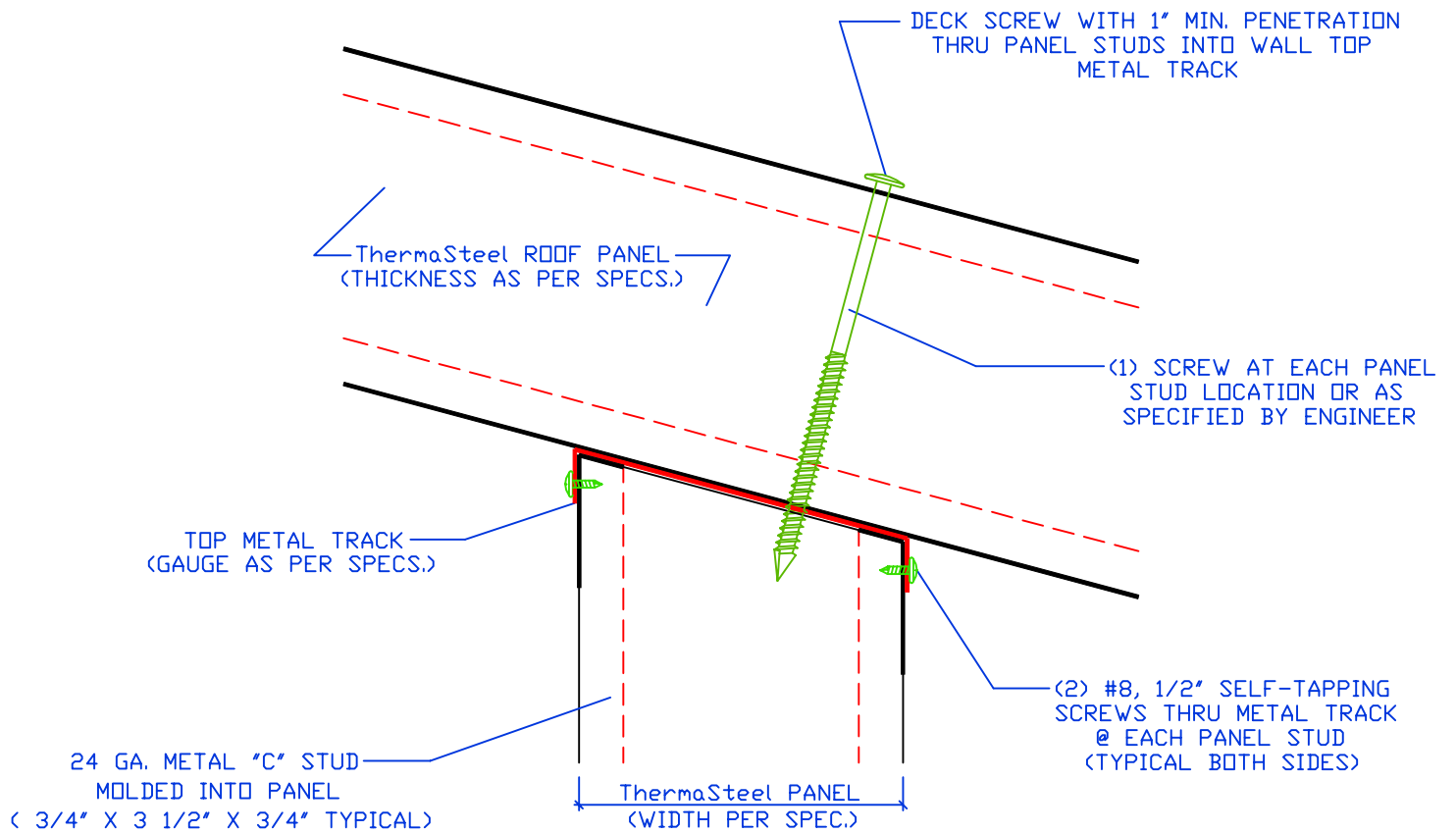

FIG C-1

ROOF PANEL CONNECTION

(WITH TOP METAL TRACK ON PANEL MOLDED TO ROOF PITCH)

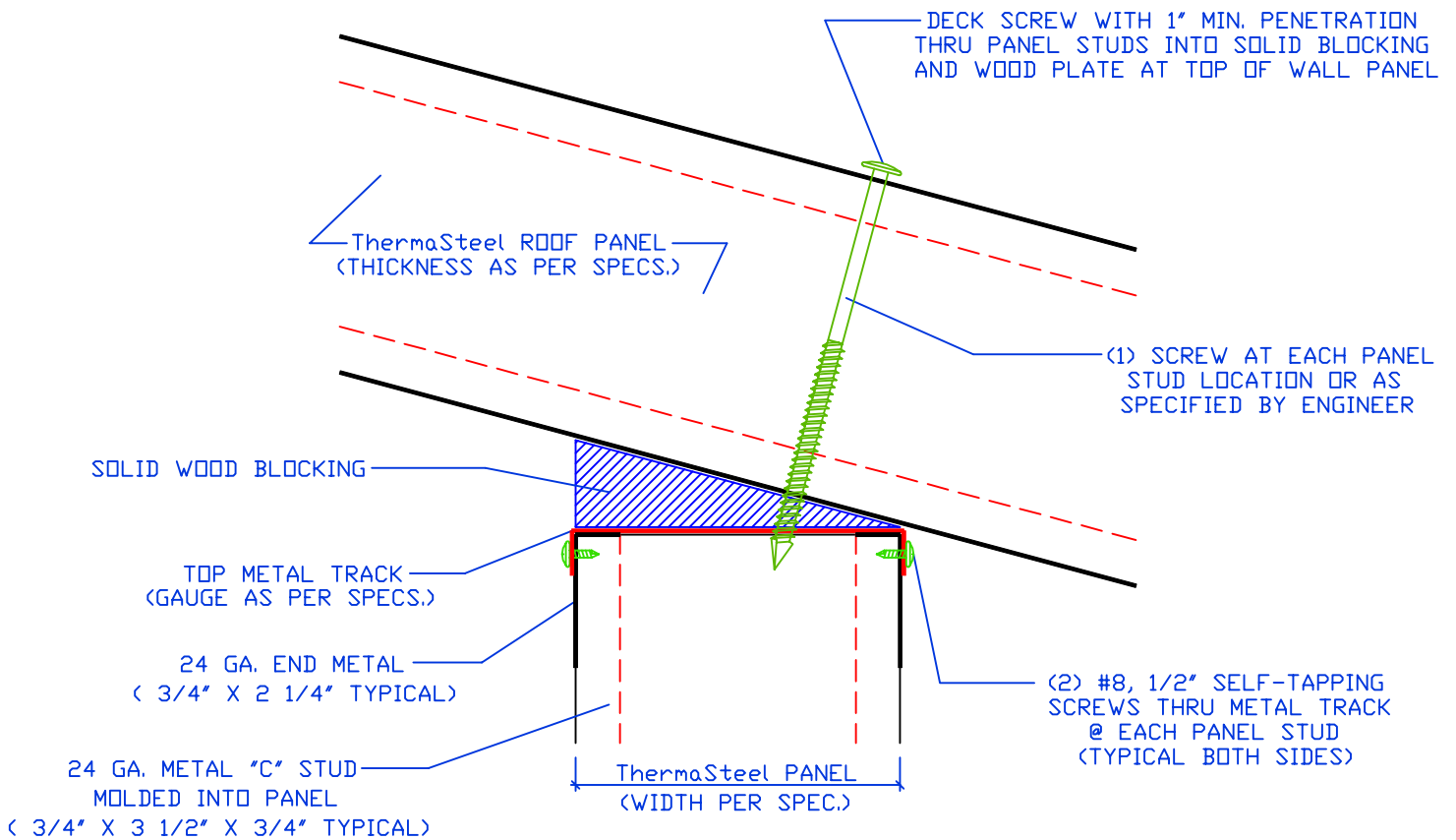

FIG C-2

ROOF PANEL CONNECTION

(WITH TOP METAL TRACK AND SOLID WOOD BLOCKING)

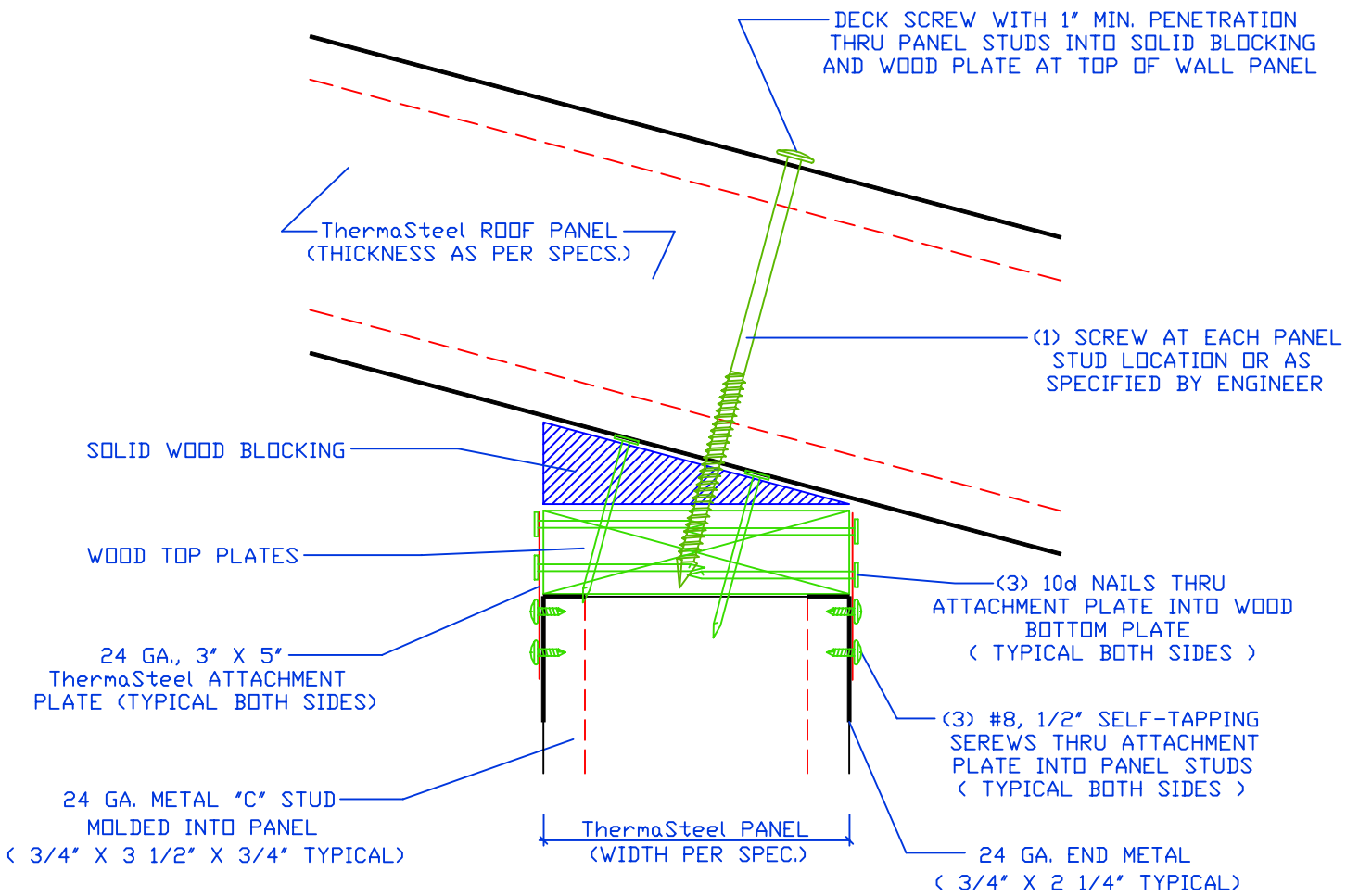

FIG C-3

ROOF PANEL CONNECTION

(WITH TOP PLATE AND SOLID WOOD BLOCKING)

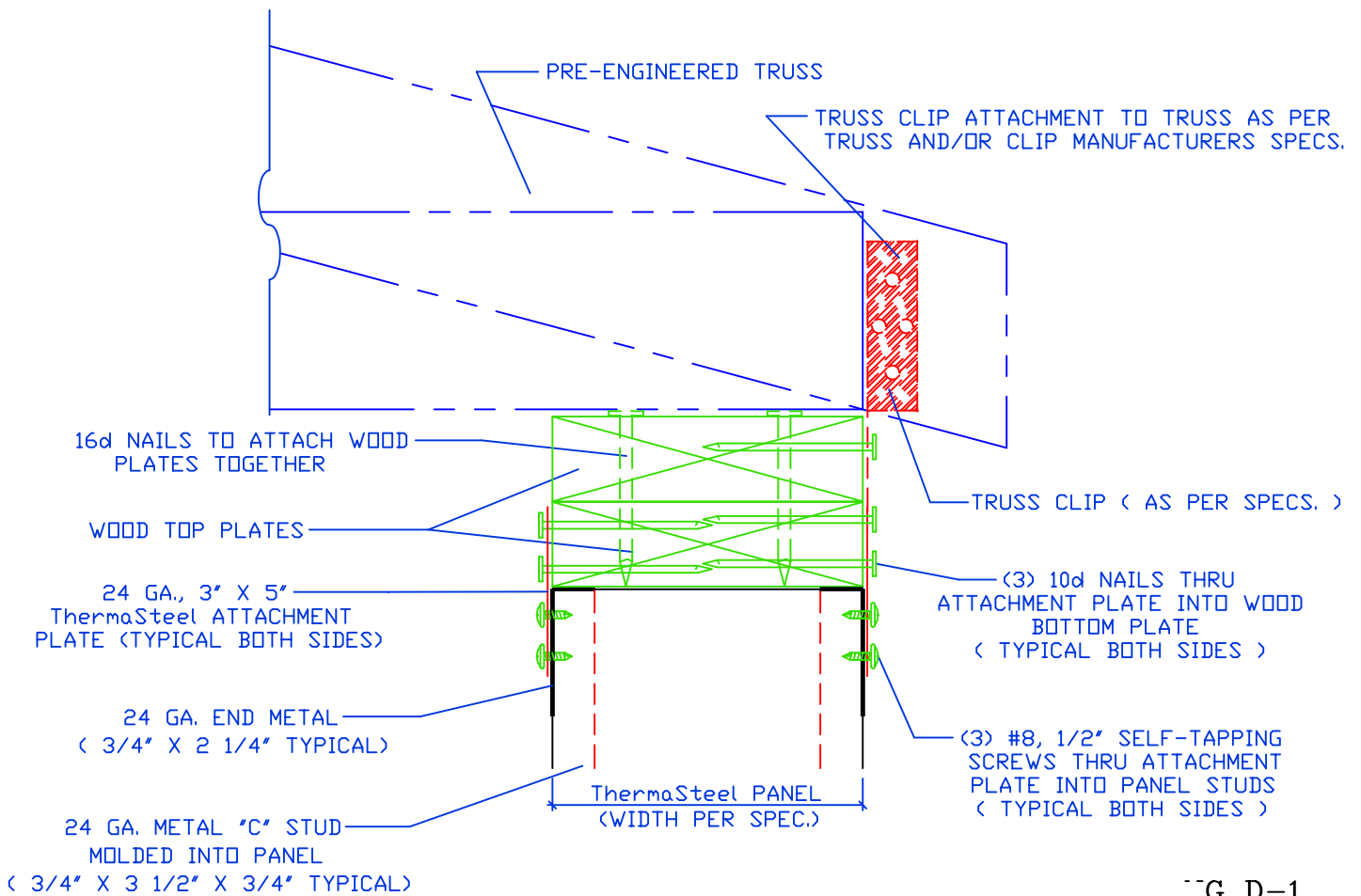

FIG D-1

PRE-ENGINEERED TRUSS CONNECTION

(WITH (2) TOP PLATES AND CLIPS AS SPECS.)

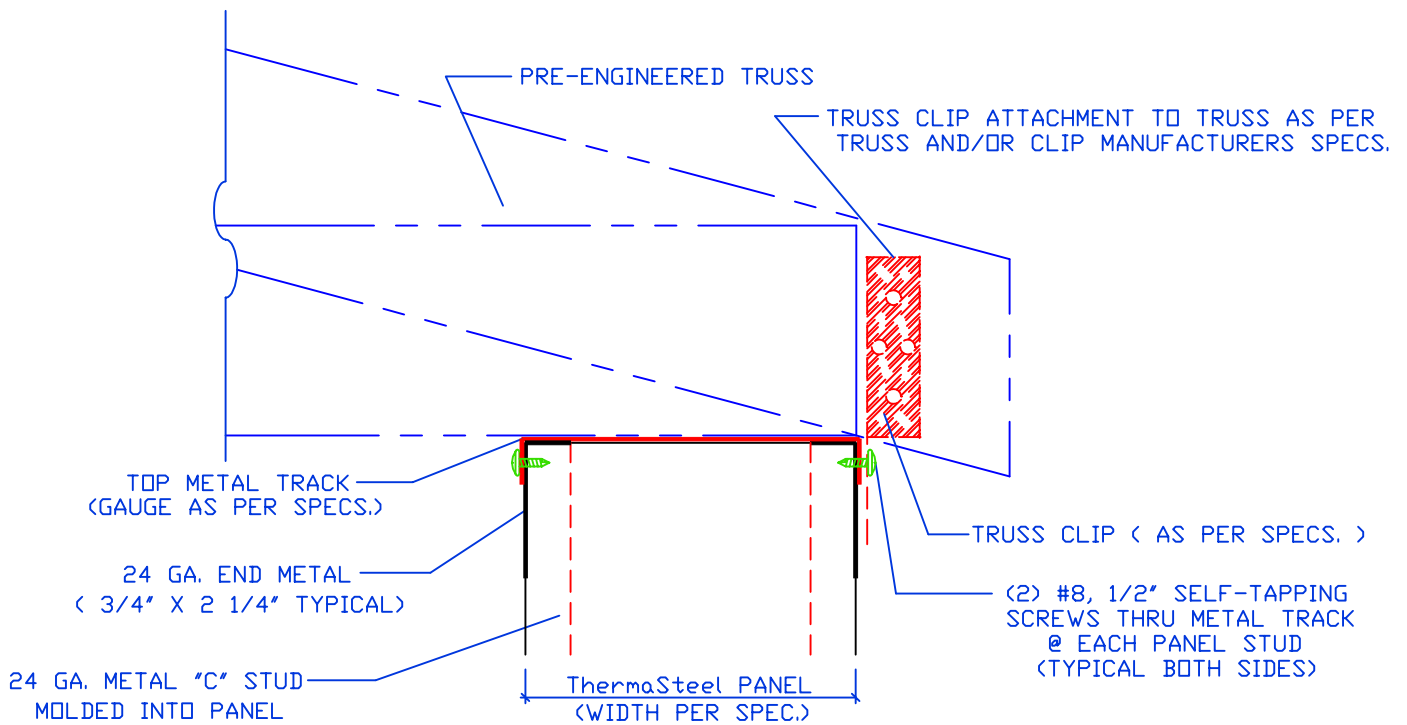
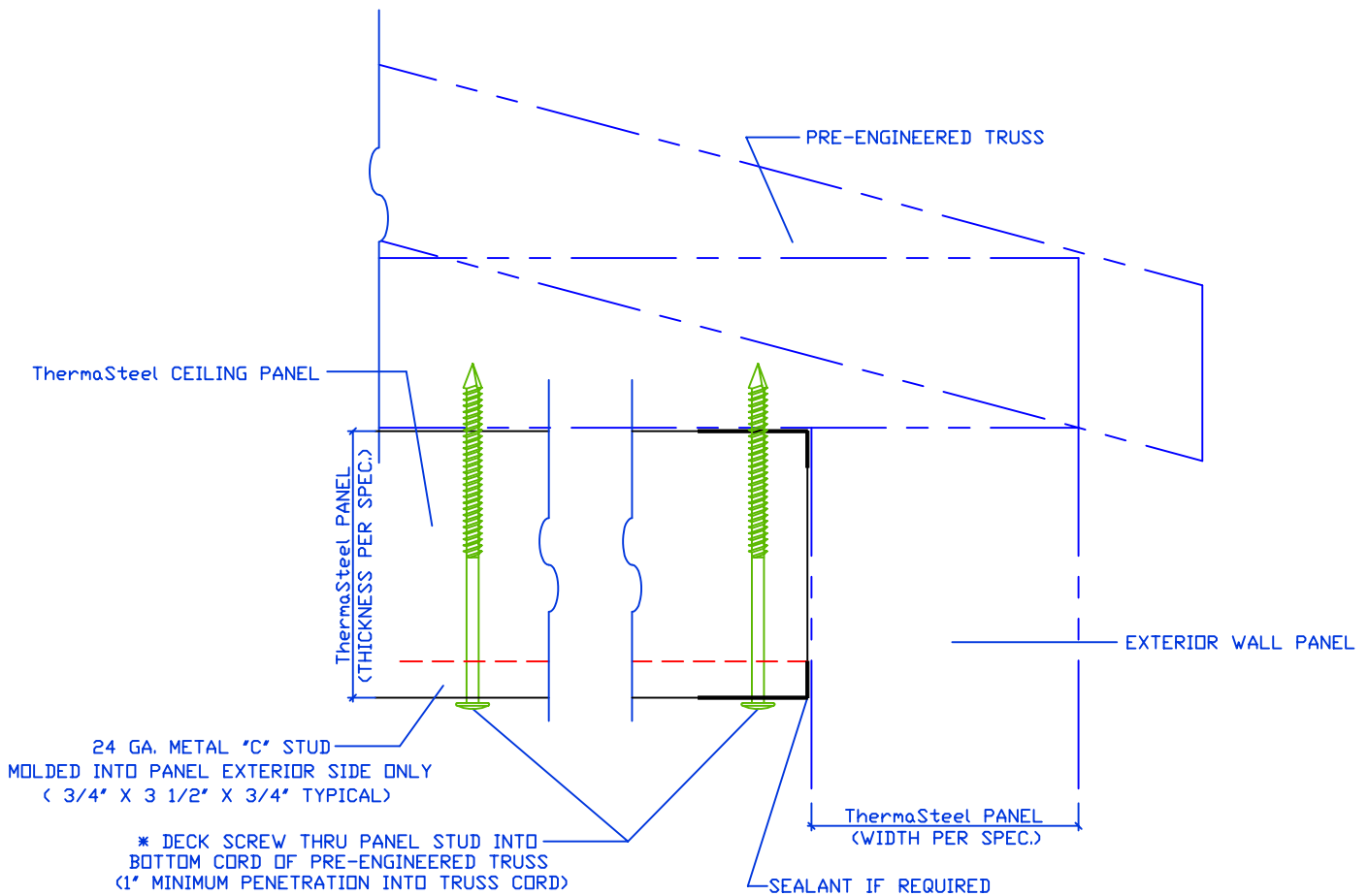

FIG D-2

PRE-ENGINEERED TRUSS CONNECTION

(WITH TOP METAL TRACK AND CLIPS AS SPECS.)



* (1) SCREW AT EACH PANEL STUD THAT CROSSES TRUSS CORD
(1" MIN. PENETRATION WITH DECK SCREW INTO TRUSS CORD)

FIG E-1

PRE-ENGINEERED TRUSS CONNECTION

(WHEN USING CEILING PANELS TO RAFTERS USE SAME PROCEDURE)

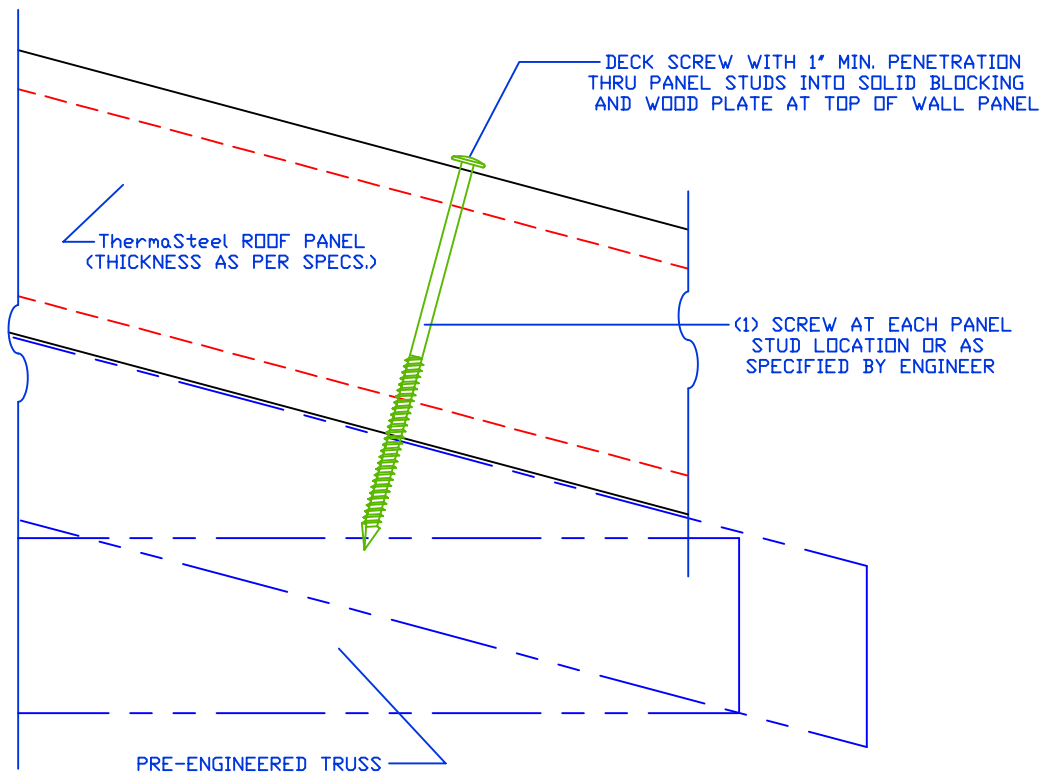

FIG F-1

PRE-ENGINEERED TRUSS CONNECTION

(WHEN USING ROOF PANELS TO RAFTERS USE SAME PROCEDURE)

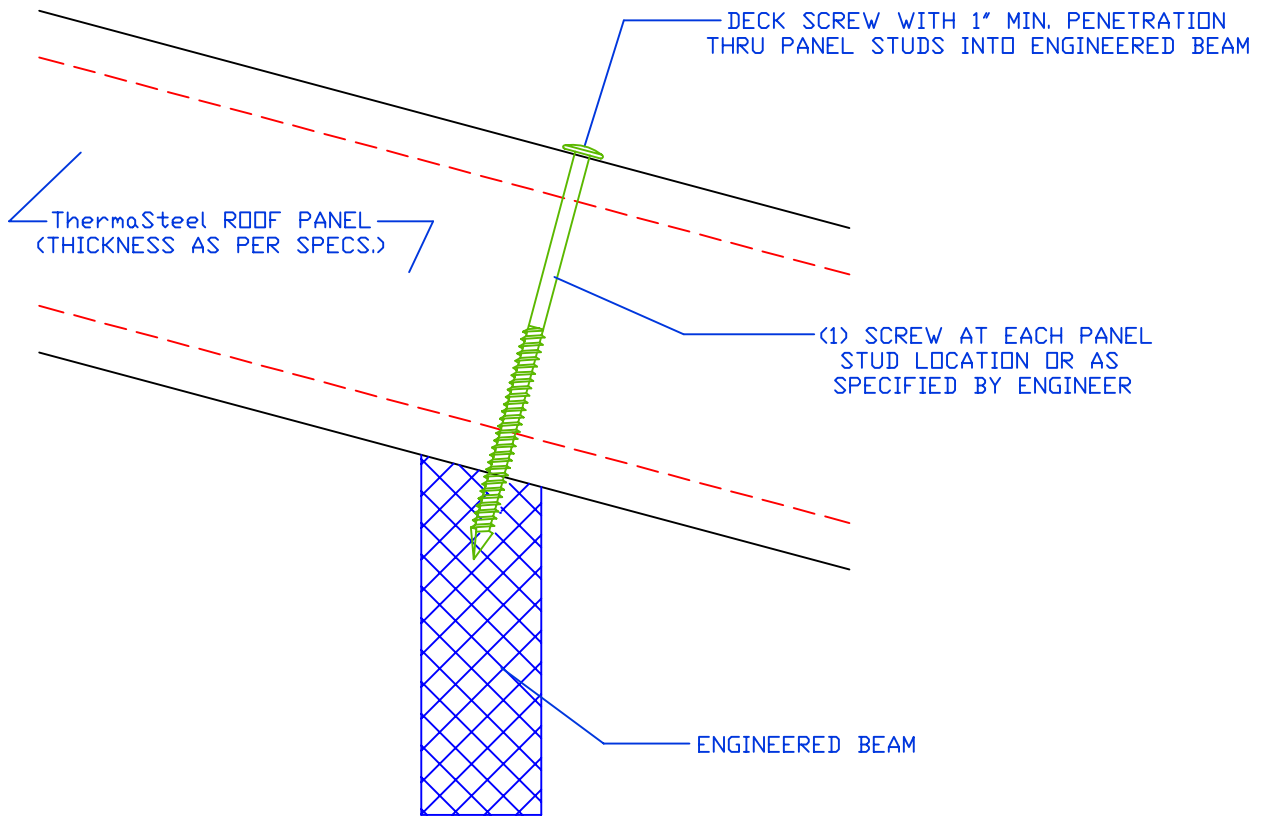
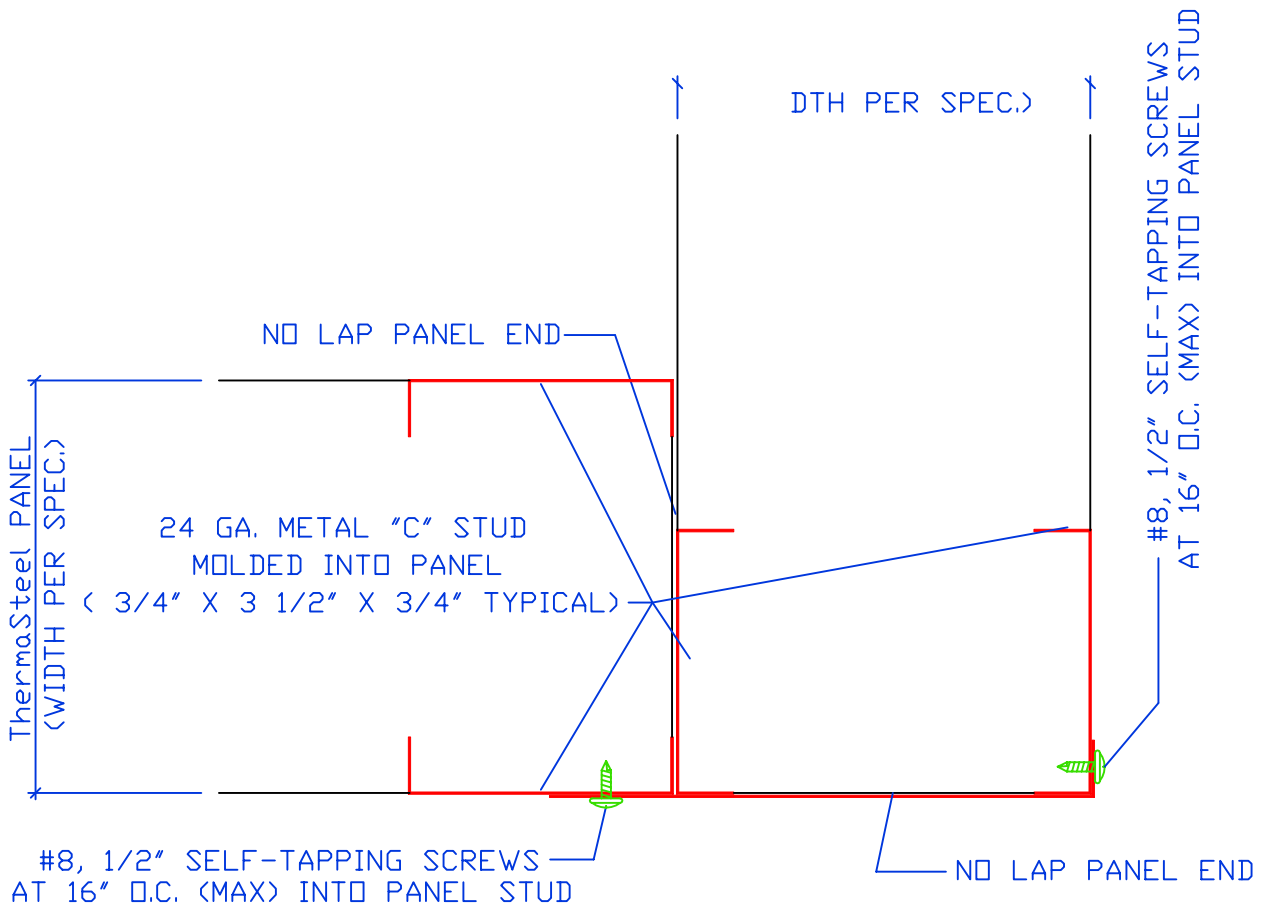

FIG F-2

ROOF PANEL CONNECTION
 (PANEL TO PRE-ENGINEERED BEAM)



PLAN VIEW
CORNER CONNECTION

FIG G-1

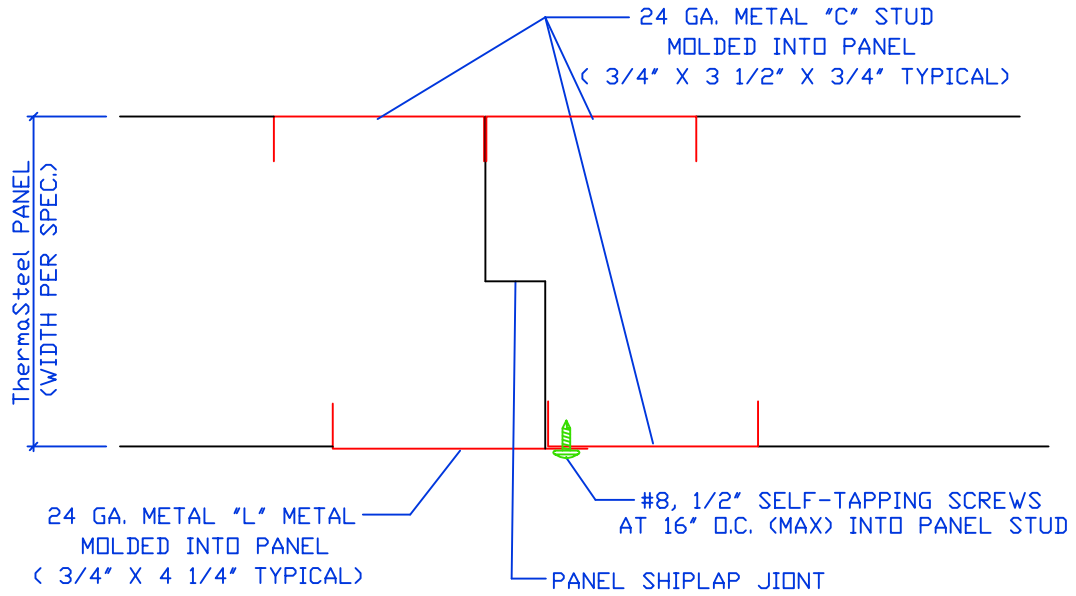

PLAN VIEW
SHIPLAP JOINT CONNECTION

FIG G-2